

BART® Guidelines for Operation



Pressure Washer

The BART system is powered by pressurized water and may be operated using a standard pressure washer. We recommend a system that supplies 2.5 to 3 gallons per minute at 2500 to 3000 psi. Follow all manufacturer safety and operational guidelines when using the pressure washer.

Please Note: If you are using a gas pressure washer to power the BART system, the pressure washer should be operated outside your shop in a well ventilated area.

Attach the pressure washer to the BART wand using the fittings supplied with the unit. Quick connect adapters may be substituted to allow for simple assembly and disassembly. Ensure that all fittings are secure before starting the pressure washer. Always shut off the pressure washer when servicing the wand.

Assembling the BART® System

See the attached assembly diagram.

1. Attach the handle (5) to the wand (1) using the washer (7) and nut (6).
2. Attach the stainless steel discharge tee (3) to one end of the PVC discharge hose (4) and secure with hose clamp (8).
3. Attach the other end of the PVC discharge hose to the BART wand and secure with hose clamp.
4. Attach the pressure gauge assembly – high pressure gauge (9), male quick connect (10) and female quick connect (11) – to the high pressure outlet of the pressure washer using quick connects 10 and 11.
5. Connect high pressure line between gauge and wand using threaded connector (12).

Operating the BART® System

1. Place the discharge tee into the vessel designated for the collection of spent abrasive. If you are using the BART 55 gallon drum with attached diffuser or the portable diffuser placed over a hopper, ensure that the discharge tee is secured in the diffuser to prevent water and abrasive from splashing out. (A small clamp may be used to achieve this result.)
2. Ensure that the water from the collection vessel can be freely returned to the waterjet tank during the operation of the unit.
 - a. *Please Note: The BART system requires an adequate amount of water in the tank to work effectively. For tanks that contain little water due to a high level of garnet, additional water can be added to the tank using a separate source. Once the water begins to return to the waterjet tank, the supplemental water source can be removed.*
3. With the BART wand valve in the off position start the pressure washer.

4. Place the BART wand between the slats of the waterjet table and allow the vacuum end of the wand to rest on the spent abrasive in the tank.
 - a. Please Note: *Do not force the wand down into the abrasive as this can restrict flow into the wand and cause a clog.*
5. Slowly open the valve on the BART wand to allow the pressurized water into the system commencing operation. Note that the wand will draw itself toward the bottom of the waterjet tank as it removes spent abrasive. As the abrasive is removed, slowly move the wand to an area where abrasive remains.
6. To discontinue use, close the valve on the wand and remove it from the waterjet tank. Turn off the pressure washer.

Maintenance

The Jet Nozzle (part #WGR00018) must be changed after 40-50 hours of use, or when a decrease in pressure/performance is noted, whichever occurs first. Failure to change the Jet Nozzle could result in premature wear of the wand. Premature wear as a result of failure to change the Jet Nozzle or failure to use the proper replacement part will void the warranty.

Troubleshooting

1. Clogging – The wand may occasionally become clogged if non-garnet items (drops) collect on the screen at the vacuum end of the unit or if the wand is forced down into the waste abrasive.
 - a. Warning: *Never remove the screen from the vacuum end of the wand. Removing the screen is a safety hazard and can cause damage to the unit.*

If a clog occurs, shut off the valve and the pressure washer before inspecting the wand. Clogs can be diagnosed by visual observation of the discharge hose and the end of the wand. If the unit is functioning properly, the discharge hose will have a continuous flow of slurry through it. If there are “voids” or air pockets in the discharge hose, there may be an obstruction at the vacuum end of the wand or inside the wand or hose. To remove the clog, close the valve on the wand and remove it from the waterjet tank. Shut off the pressure washer. Clear the debris and resume use of the system.

If you have questions regarding the proper operation of your BART unit, please contact your Regional Sales Manager or Barton Sales at 800-741-7756.

Due to continuing product improvement, the information contained in this document is subject to change without notice. Barton Mines Corporation shall not be held liable for technical or editorial omissions made herein, nor for any incidental or consequential damage resulting from the use of this material.

® BART is a registered trademark of Barton Mines Corporation.

U.S. and foreign patents pending.

Parts List

Barton Part #	Description
WGRWAND1	BART Wand with 1"ID Discharge Hose

Item	Barton Part #	Quantity	Description
2	WGR00005	1	Bart Nozzle Wrench
3	WGR00006	1	Bart Diffuser Tee
4	WGR00003	1	1" ID Discharge Hose
5	WGR00007	1	Handle
6	WGR00008	1	Handle Nut
7	WGR00009	2	Handle Washer
8	WGR00010	2	Hose Clamps
9	WGR00011	1	Pressure Gauge
10	WGR00012	1	Male Quick Connect
11	WGR00013	1	Female Quick Connect
12	WGR00014	1	Threaded Connector
13	WGR00015	1	Brass Adapter
14	WGR00016	1	1/2" Nipple
15	WGR00017	1	Valve
16	WGR00018	1	Jet Nozzle
17	WGR00019	1	Screen Bolts
18	WGR00020	1	Screen Washers
19	WGR00021	1	Screen
	WGR00023	1	Screen (New Style)

Optional Accessories

Barton Part #	Description
WGR00001	BART 55 Gallon Drum w/Attached Diffuser
WGR00002	BART Portable Diffuser

Assembly Diagram

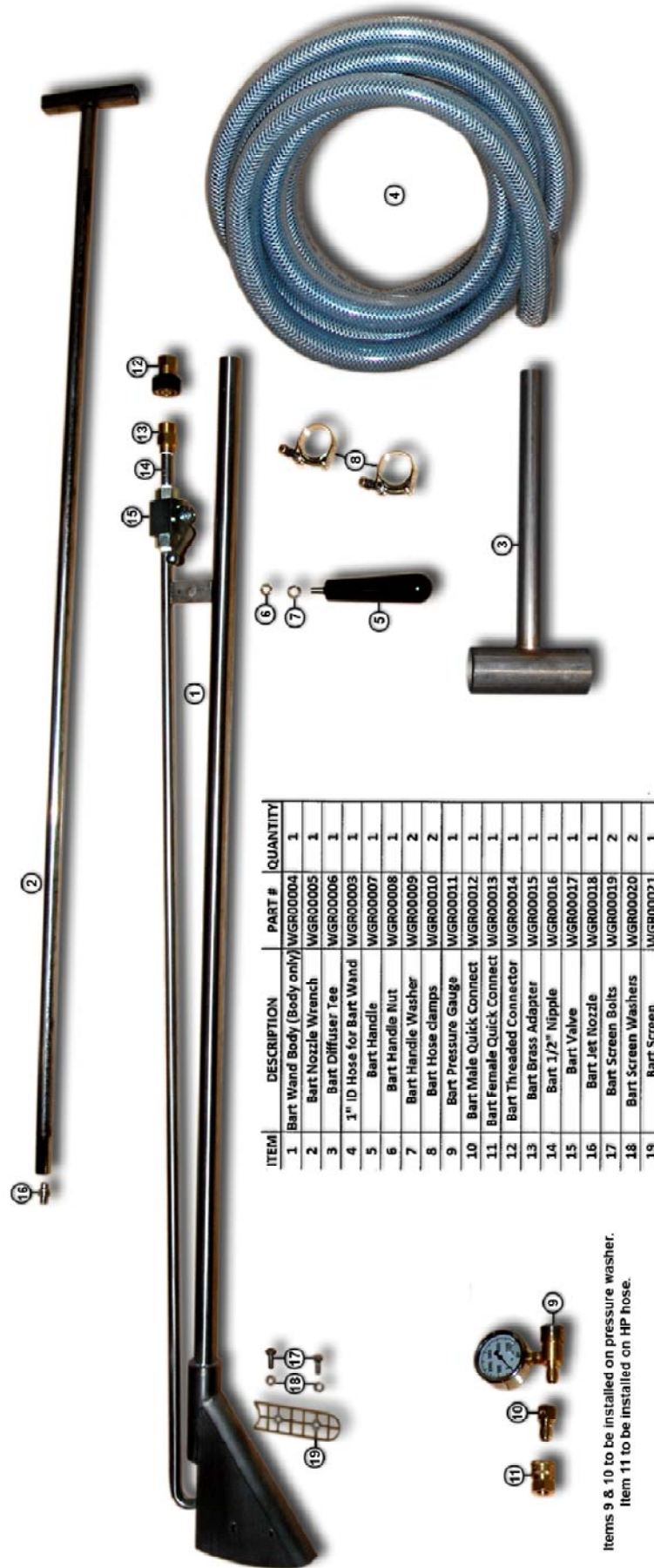

ITEM	DESCRIPTION	PART #	QUANTITY
1	Bart Wand Body (Body only)	WGR00004	1
2	Bart Nozzle Wrench	WGR00005	1
3	Bart Diffuser Tee	WGR00006	1
4	1" ID Hose for Bart Wand	WGR00003	1
5	Bart Handle	WGR00007	1
6	Bart Handle Nut	WGR00008	1
7	Bart Handle Washer	WGR00009	2
8	Bart Hose clamps	WGR00010	2
9	Bart Pressure Gauge	WGR00011	1
10	Bart Male Quick Connect	WGR00012	1
11	Bart Female Quick Connect	WGR00013	1
12	Bart Threaded Connector	WGR00014	1
13	Bart Brass Adapter	WGR00015	1
14	Bart 1/2" Nipple	WGR00016	1
15	Bart Valve	WGR00017	1
16	Bart Jet Nozzle	WGR00018	1
17	Bart Screen Bolts	WGR00019	2
18	Bart Screen Washers	WGR00020	2
19	Bart Screen	WGR00021	1

Items 9 & 10 to be installed on pressure washer.
Item 11 to be installed on HP hose.